



HEATING & COOLING

INDUCED-COMBUSTION

58TUA & 58TMA

GAS FURNACE

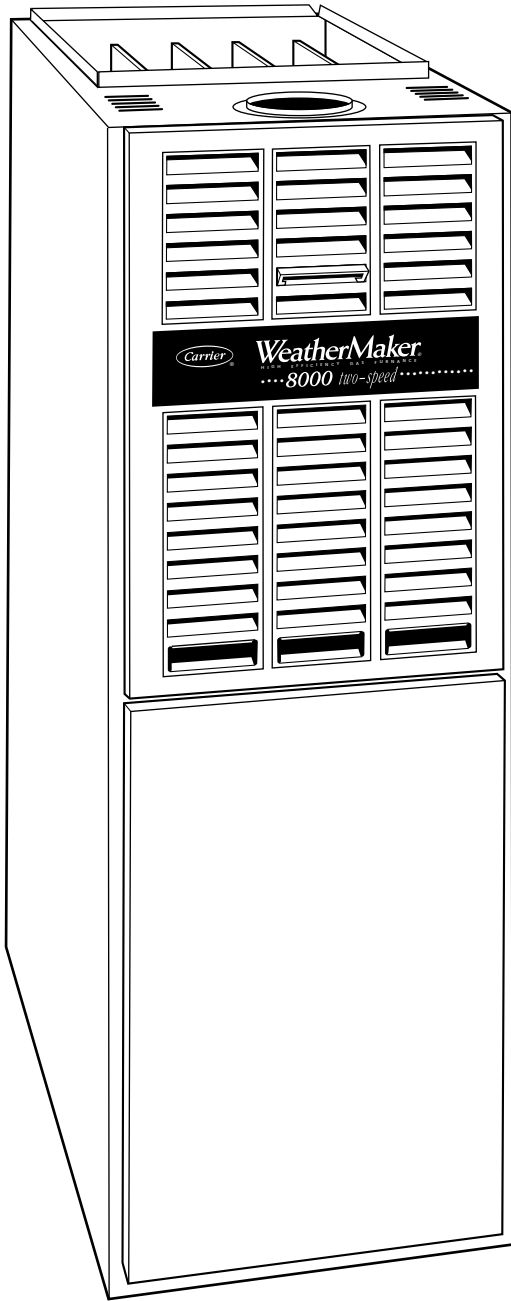

USER'S INFORMATION MANUAL FOR THE OPERATION AND MAINTENANCE OF YOUR NEW GAS-FIRED FURNACE

**NOTE TO INSTALLER:
THIS MANUAL MUST BE LEFT WITH
THE EQUIPMENT USER.**

⚠ WARNING: If the information in this manual is not followed exactly, a fire or explosion may result causing property damage, personal injury or loss of life.

- Do not store or use gasoline or other flammable vapors and liquids in the vicinity of this or any other appliance.
- **WHAT TO DO IF YOU SMELL GAS:**
- Do not try to light any appliance.
- Do not touch any electrical switch; do not use any phone in your building.
 - Immediately call your gas supplier from a neighbor's phone. Follow the gas supplier's instructions.
 - If you cannot reach your gas supplier, call the fire department.
- Installation and service must be performed by a qualified installer, service agency or the gas supplier.

Do not use this furnace if any part has been under water. Immediately call a qualified service technician to inspect the furnace and to replace any part of the control system and gas control which has been under water.

WELCOME TO TODAY'S GENERATION OF COMFORT

Congratulations! Your new, high-efficiency gas furnace is a sound investment which will reward you and your family with years of warm memories winter after winter.

Not only is your new furnace energy efficient, it is also extremely reliable and supplies superior home comfort. Spend just a few minutes with this booklet to learn about the operation of your new furnace and the small amount of maintenance it takes to keep it operating at peak efficiency. Years went into the development of your new furnace. Take a little time now to assure its most efficient operation for years to come.

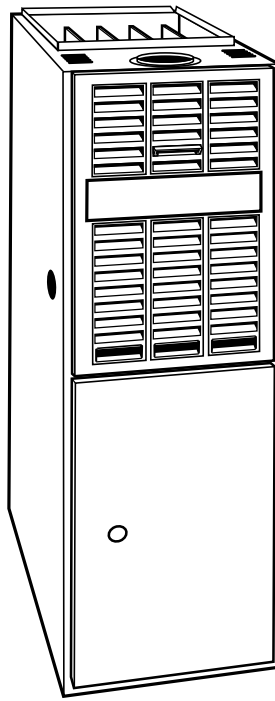

1

**MODEL 58TUA
UPFLOW FURNACE**

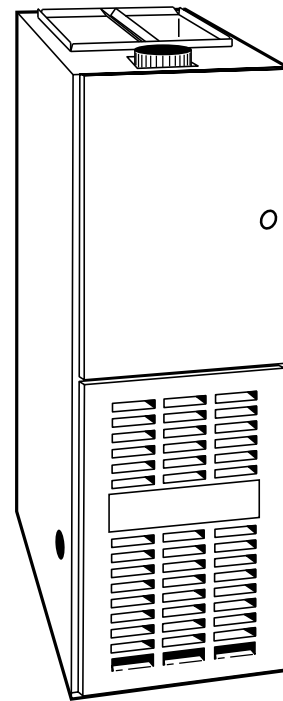

2

**MODEL 58TMA
DOWNFLOW/
HORIZONTAL FURNACE**

UPFLOW FURNACE COMPONENTS

- 1 Relief Box
- 2 Rating Plate
- 3 Gas Valve Control Knob or Electric Switch (On/Off)
- 4 2-Stage Gas Valve
- 5 Manual Reset Flame Rollout Switch
- 6 Gas Burner
- 7 Flame Sensor
- 8 Hot Surface Ignitor
- 9 Status LED Light
- 10 Blower and Blower Motor
- 11 Draft Safeguard Tube and Switch
- 12 Gas Manifold
- 13 Blower Door Safety Switch
- 14 Filter Retainer
- 15 Air Filter

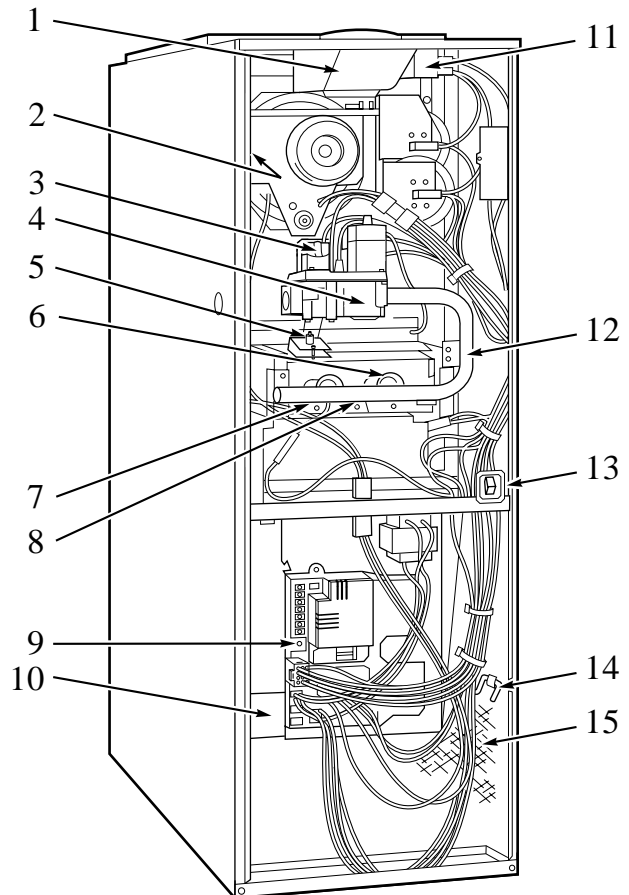

3

DOWNFLOW/HORIZONTAL FURNACE COMPONENTS

- 1 Manual Reset Auxiliary Limit Switch
- 2 Blower and Blower Motor
- 3 Relief Box
- 4 Gas Valve Control Knob or Electric Switch (On/Off)
- 5 2-Stage Gas Valve
- 6 Gas Burner
- 7 Rating Plate
- 8 Status LED Light
- 9 Blower Door Safety Switch
- 10 Draft Safeguard Tube and Switch
- 11 Manual Reset Flame Rollout Switch (2)
- 12 Gas Manifold
- 13 Hot Surface Ignitor
- 14 Flame Sensor

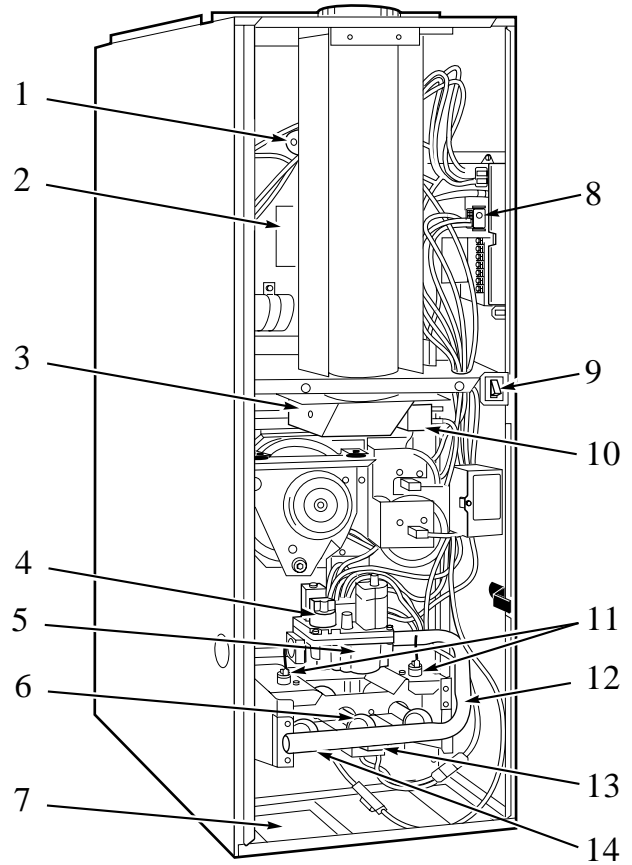

4

IMPORTANT FACTS

Your furnace must have adequate airflow for efficient combustion and safe ventilation. Do not enclose it in an airtight room or “seal” it behind solid doors.

To minimize the possibility of serious personal injury, fire, furnace damage, or improper operation, **carefully follow these safety rules:**

- Keep the area around your furnace free of combustible materials, gasoline, and other flammable liquids and vapors.

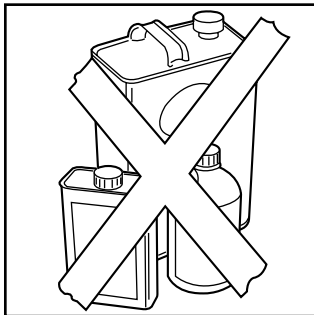

- Do not cover the furnace, store trash or debris near it, or in any way block the flow of fresh air to the unit.
- Combustion air must be clean and uncontaminated with chlorine or fluorine. These compounds are present in many products around the home, such as: water softener

salts, laundry bleaches, detergents, adhesives, paints, varnishes, paint strippers, waxes, and plastics.

Make sure the combustion air for your furnace does not contain any of these compounds. During remodeling be sure the combustion air is fresh and uncontaminated. If air with vapors of these compounds is burned in your furnace, the heat exchangers and metal vent system may deteriorate.

- A furnace installed in an attic or other insulated space must be kept free and clear of insulating material. Examine the furnace area when installing the furnace or adding more insulation. Some materials may be combustible.

NOTE: Do not use this furnace if any part has been under water. Immediately call a qualified service technician to inspect the furnace and to replace any part of the control system, electrical components and any gas control which has been under water.

NOTE: The qualified installer or agency must use only factory-authorized replacement parts, kits, and accessories when servicing this product.

This furnace contains safety devices which must be manually reset. If the furnace is left unattended for an extended period of time, have it checked periodically for proper operation. This precaution will prevent problems associated with no heat, such as frozen water pipes, etc. See “Before You Request a Service Call” section in this manual.

SAFETY CONSIDERATIONS

Installing and servicing heating equipment can be hazardous due to gas and electrical components. Only trained and

5

3

qualified personnel should install, repair, or service heating equipment.

Untrained personnel can perform basic maintenance functions such as cleaning and replacing air filters. All other operations must be performed by trained service personnel. Observe safety precautions in this manual, on tags and labels attached to the furnace, and other safety precautions that may apply.

Recognize safety information. This is the safety-alert symbol . When you see this symbol on the furnace and in instructions or manuals, be alert to the potential for personal injury.

Understand the signal words DANGER, WARNING, and CAUTION. These words are used with the safety-alert symbol. DANGER identifies the most serious hazards which **will** result in severe personal injury or death. WARNING signifies hazards which **could** result in personal injury or death. CAUTION is used to identify unsafe practices which **would** result in minor personal injury or product and property damage.

STARTING YOUR FURNACE

Instead of a continuously burning pilot flame, your furnace uses an automatic hot surface ignition system to light the burners each time the thermostat turns your furnace on.

Follow these important safeguards:

- Never attempt to manually light the burners with a match or other source of flame.

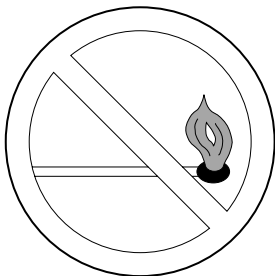

- Read and follow the operating instructions on the furnace, especially the item that reads as follows:

Wait 5 minutes to clear out any gas. Then smell for gas, including near the floor. If you smell gas, **STOP!** Follow “B” in the above safety information on this label. If you don’t smell gas, go to the next step.

- If a suspected malfunction occurs with your gas control system, such as the burners do not light when they should, refer to the shutdown procedures on the furnace or see “Shutting Down your Furnace” section in this manual, then call your dealer as soon as possible.

WARNING

Should overheating occur or the gas valves fail to shut off the gas supply, turn off the manual gas valve to the furnace BEFORE turning off the electrical supply. (See Fig. 8.) A failure to follow this warning could result in a fire or explosion, and personal injury or death.

- **Check Air Filter:** Before attempting to start your furnace, be sure the furnace filter is clean and in place. (See the maintenance section of this manual.) Then proceed as follows:

STEPS FOR STARTING YOUR FURNACE

1. Set your room thermostat to the lowest temperature setting. (See Fig. 7.)
2. Close the external manual gas valve. (See Fig. 8.)

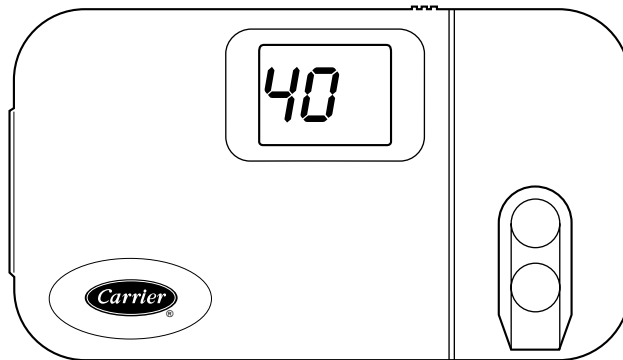

7

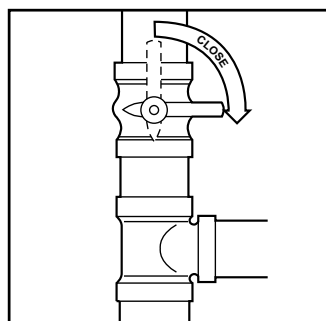

8

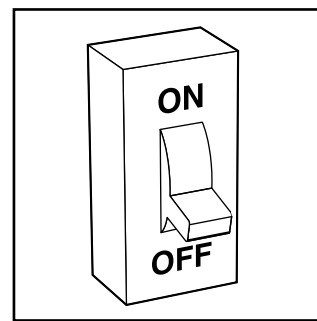

9

3. Turn off electrical supply to the furnace. (See Fig. 9.)
4. Remove the furnace access door(s).
 - a. Downflow/Horizontal—Remove blower door after removing 2 screws first, then remove the control door. (See Fig. 10.)
 - b. Upflow—Remove control door. (See Fig. 11.)

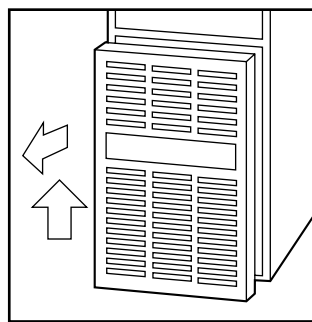

10

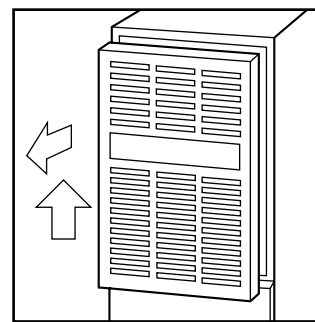

11

5. The gas valve will have EITHER a control knob or control switch to turn off and on. Turn the control knob or switch on the gas valve to the OFF position and wait 5 minutes. (See Fig. 12 or 13.)
6. After waiting 5 minutes, turn the control knob or switch on the gas valve to the ON position. (See Fig. 14 or 15.)
7. Replace the access door(s). See Fig. 16 for upflow and Fig. 17 for downflow. Replace control door first on downflow furnaces. Replace blower door and secure with 2 screws.
8. Turn ON the electrical supply to the furnace. (See Fig. 18.)

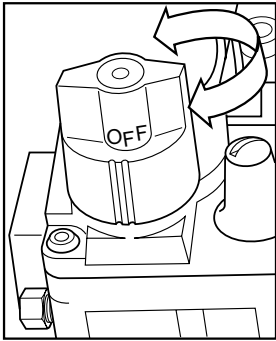

12

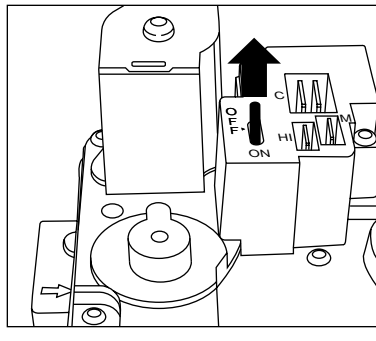

13

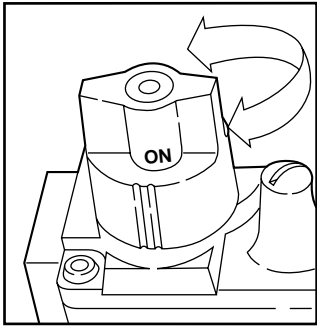

14

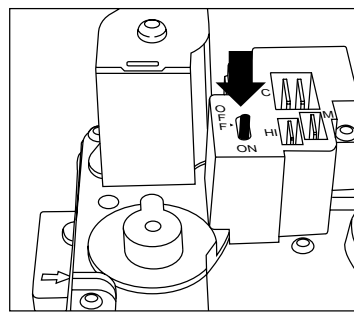

15

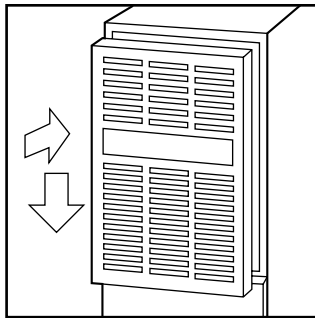

16

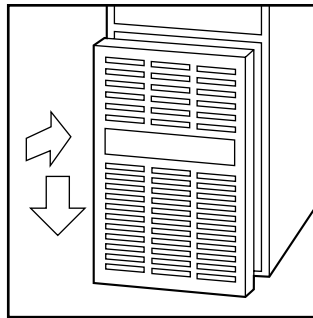

17

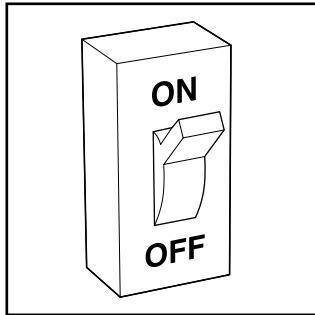

18

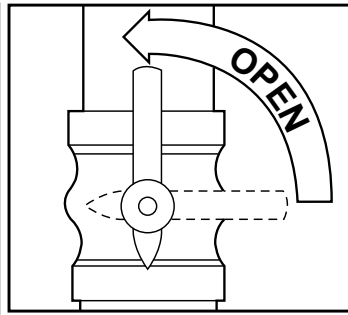

19

9. Open the external manual gas valve. (See Fig. 19.)

10. Set the room thermostat to a temperature slightly above the room temperature. This will automatically signal the furnace to start. The inducer motor will start, and the hot surface ignitor will energize. When hot, the ignitor will have an orange glow.

11. After 15 to 70 sec, the gas valve permits gas to flow to the main burners where it is ignited. Hot flames begin to warm the furnace's heat exchanger. After a time delay of approximately 45 sec, the furnace blower is switched on.

NOTE: If the main burners fail to ignite, the furnace control system will go through 3 more ignition cycles. If burners

still fail to ignite, the system will lockout. (Under some circumstances the furnace may reset from lockout and attempt to ignite if a call for heat still exists.) If lockout occurs or the blower does not come on, refer to the shutdown procedures on the furnace or see "Shutting Down Your Furnace" section in this manual, and call your dealer for service.

12. Set your thermostat to the temperature that satisfies your comfort requirements. **SUGGESTION:** Setting the thermostat back a few degrees and compensating for the difference with warmer clothing can make a big difference in your fuel consumption. The few degrees at the top of your thermostat "comfort level" are the most costly degrees to obtain.

When the room temperature drops below the temperature selected on the thermostat, the furnace will switch on automatically. When the room temperature reaches the setting selected on the thermostat, the furnace will automatically switch off.

Some thermostats have a "FAN" switch with 2 selections, AUTO and ON. When thermostat is set on AUTO, the furnace blower cycles on and off, controlled by the thermostat. In ON position, the furnace blower runs continuously except for a 77-sec delay at the "call for heat." This keeps the temperature level in your home more evenly balanced. It also continuously filters the indoor air. When the FAN switch is moved from ON to AUTO, the furnace blower will continue running for 90 sec before stopping.

SHUTTING DOWN YOUR FURNACE

Should you ever suspect a malfunction in your furnace, you will need to turn the furnace off. The following procedures must be followed:

1. Set your room thermostat to the lowest temperature setting. (See Fig. 20.)
2. Close the manual gas valve that is located outside of the furnace cabinet. (See Fig. 8.)
3. Turn off electrical power to your furnace. (See Fig. 21.)

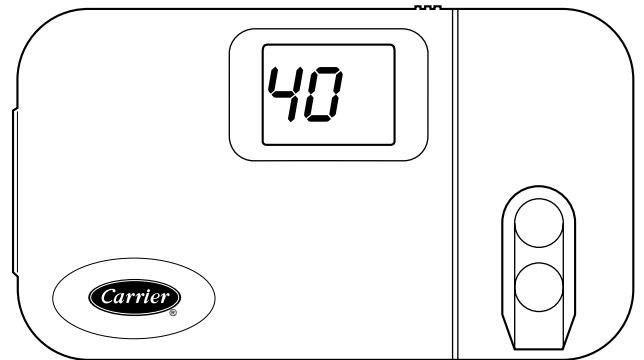

20

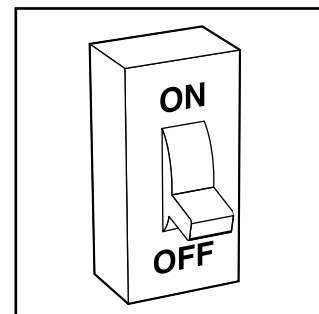

21

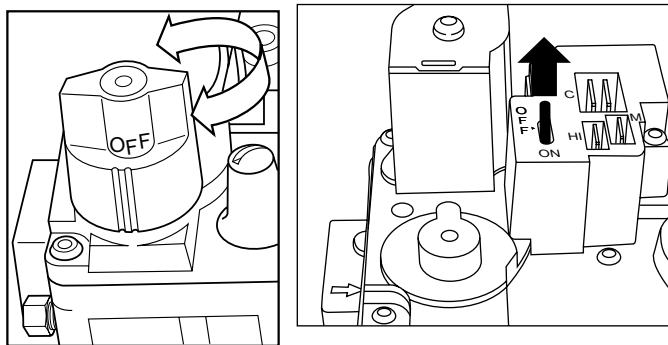

22

23

4. Remove the control access door on your furnace. (See Fig. 10 or 11.) On upflow furnaces, removing the blower access door is not required.
5. Turn the control knob or switch on the gas valve to the OFF position. (See Fig. 22 or 23.)
6. Replace the control access door. (See Fig. 16 or 17.)
7. If the furnace is being shut down because of a malfunction, call your dealer as soon as possible.

PERFORMING ROUTINE MAINTENANCE

With proper maintenance and care, your furnace will operate economically and dependably. Basic maintenance, which can easily be accomplished by someone who follows the directions, is found on this and the following pages. However, before beginning maintenance, follow these safety precautions:

⚠ WARNING

Turn off electrical power supply to your furnace before removing the access doors to service or perform maintenance. A failure to follow this warning could result in personal injury or death.

⚠ CAUTION

Although special care has been taken to minimize sharp edges, be extremely careful when handling parts or reaching into the furnace.

FILTERING OUT TROUBLE

A dirty filter will cause excessive stress on the furnace, heat exchanger, and blower motor and can cause it to overheat and automatically shut down. The furnace filter should be checked every 3 or 4 weeks and cleaned if necessary.

If installed with factory specified disposable media filter, check or replace filter before each heating and cooling season. Replace disposable media filter at least once a year.

If your furnace filter needs replacing, be sure to use the same size and type of filter that was originally supplied. Use the Furnace Filter Table and match your furnace size with the proper filter size.

⚠ CAUTION

Never operate your furnace without a filter in place. Doing so may damage the furnace blower motor. An accumulation of dust and lint on internal parts of your furnace can cause a loss of efficiency.

The air filter for upflow furnaces is normally located in the blower compartment. (See Fig. 3) or in the factory-supplier filter cabinet attached to the side or bottom of the blower cabinet. Filters for the downflow furnaces are normally located in the return-air plenum above the blower. If air filter has been installed in another location, contact your dealer for instructions. To inspect, clean and/or replace the air filter(s), follow these steps:

• Upflow Furnaces Only—

1. Turn off the electrical supply to the furnace. (See Fig. 21.)
2. Remove door/access panel
 - AIR FILTER(S) LOCATED IN BLOWER COMPARTMENT
Remove control and blower access doors. (See Fig. 11)
 - AIR FILTER LOCATED IN FILTER CABINET
Remove filter cabinet door (See Fig. 30 and 31)
NOTE: It will be necessary to remove 1 thumbscrew

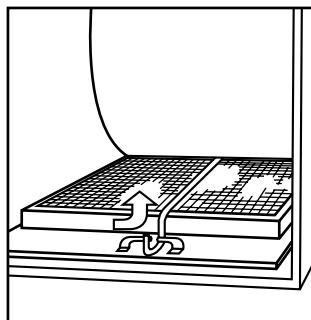

24

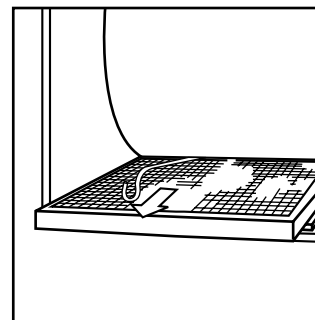

25

3. Remove air filter from furnace.
 - AIR FILTER LOCATED IN BLOWER COMPARTMENT:
 - a) Slide filter retainer sideways until it is free of latch. (See Fig. 24)
 - b) Gently remove air filter and carefully turn the dirty side up (if dirty) to avoid spilling dirt from the filter. (see Fig. 25)
 - AIR FILTER LOCATED IN FILTER CABINET:
 - a. Slide air filter out of furnace. Keep dirty side up (if dirty) to avoid spilling dirt. (See Fig. 32 and 33)
4. Inspect the filter. If torn, replace it.

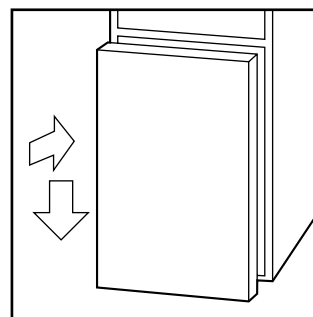

26

NOTE: If washable filter that was shipped with the furnace has been replaced by:

- a) Factory specified disposable media filter – Do not clean. If dirty, replace only with media filter having the same part number and size. Install with airflow direction arrow pointing towards blower.
- b) Electronic air cleaner (EAC) – Refer to EAC owner's Manual for maintenance information.

- Wash filter (if dirty) in sink, bathtub, or outside with a garden hose. Always use cold tap water. A mild liquid detergent may be used if necessary. Spray water through filter in the opposite direction of airflow. Allow filter to dry.
- Reinstall clean air filter
- Reinstall filter retainer (for blower compartment locations only)
- Replace control and blower doors (See Fig. 26 and 16) or filter cabinet door (Fig. 34 and 35)
- Turn on electrical supply to furnace (see Fig 18).

NOTE: Two filters may be required in some upflow models if side return ducts are used. The procedure listed above may be used to remove side filters.

• **Downflow/Horizontal Furnaces Only:**

Two filters are located in the return-air plenum above the blower (above line-of-sight) resting in the V-shaped channel on top of the furnace. (See Fig. 27.)

- Turn off electrical supply to the furnace. (See Fig. 21.)
- Remove 2 screws from blower access door and remove the door.
- Remove the left-side filter by tipping the filter toward the center and raising it from the V-shaped channel in which it rests. (See Fig. 27 and 28.)
- Lower filter down along side of the blower and remove from the furnace.
- To remove the right-side filter, lift from V-shaped channel and remove through left side the same way as left-side filter.
- Inspect the filter. If torn, replace the filter.
- Wash the filter (if dirty) in a sink, bathtub, or outside with a garden hose. Always use cold tap water. A mild liquid detergent may be used if necessary. Spray water through the filter in opposite direction of airflow through the cross-mesh binding (when present) side. Allow filter to dry.
- Reinstall the clean filters.

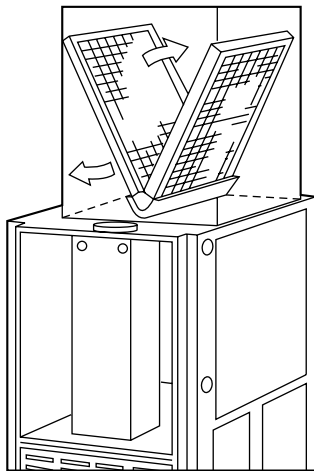

27

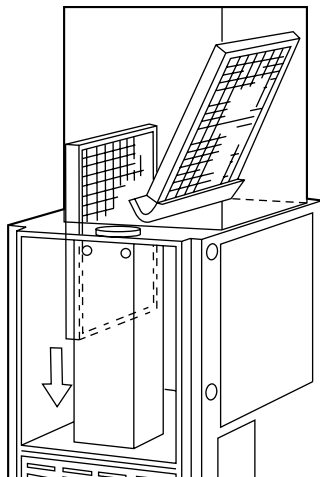

28

- Replace blower door and secure with 2 screws. Turn on electrical supply to your furnace. (See Fig. 18.)

UPFLOW/HORIZONTAL FURNACE AIR FILTER TABLE

AIR FILTER LOCATED IN BLOWER COMPARTMENT			
FURNACE CASING WIDTH (IN.)	FILTER SIZE (IN)		FILTER TYPE
	Side Return	Bottom Return	
14-3/16	(1) 16 x 25 x 1*	(1) 14 x 25 x 1	Cleanable
17-1/2	(1) 16 x 25 x 1*	(1) 16 x 25 x 1*	Cleanable
21	(1) 16 x 25 x 1	(1) 20 x 25 x 1*	Cleanable
24-1/2	(1 or 2) 16 x 25 x 1	(1) 24 x 25 x 1*	Cleanable
AIR FILTER LOCATED IN FILTER CABINET			
FILTER CABINET HEIGHT (IN)	FILTER SIZE (IN)	FILTER TYPE	
16	(1) 16 x 25 x 1* or (1) 16 x 25 x 4-5/16	Cleanable Disposable	
20	(1) 20 x 25 x 1* or (1) 20 x 25 x 4-5/16	Cleanable Disposable	
24	(1) 24 x 25 x 1* or (1) 24 x 25 x 4-5/16	Cleanable Disposable	

DOWNFLOW/HORIZONTAL FURNACE FILTER TABLE (IN.)

FURNACE CASING WIDTH	FILTER SIZE (IN)	FILTER TYPE
14-3/16	(2) 16 x 20 x 1*	Cleanable
17-1/2	(2) 16 x 20 x 1*	Cleanable
21	(2) 16 x 20 x 1*	Cleanable
24-1/2	(2) 16 x 20 x 1*	Cleanable

* Factory provided with the furnace. Filters may be field modified by cutting filter material and support rods (3) in filters. Alternate sizes and additional filters may be ordered from your dealer.

⚠ CAUTION

Use care when cutting support rods in filters to protect against flying pieces and sharp rod ends. Wear safety glasses, gloves, and appropriate protective clothing. Failure to follow this caution could result in personal injury.

COMBUSTION AREA AND VENT SYSTEM

Inspect the combustion area and vent system before each heating season. An accumulation of dirt, soot, or rust can mean a loss of efficiency and improper performance. Buildups on the main burners can cause faulty firing. This “delayed ignition” is characterized by an alarmingly loud sound. If your furnace makes a loud noise when the main burners are ignited, shut down the furnace and call your servicing dealer.

Use your flashlight and follow these steps for inspecting the combustion area and vent system of your furnace:

- Turn off electrical supply to the furnace and remove the access doors. (See Fig. 9, and 10 or 11.)
- Carefully inspect the gas burner for dirt, rust, or scale (see Fig. 29). Inspect the relief box, flue connection area, and the vent pipe for rust.

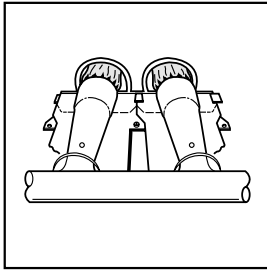

29

NOTE: If dirt, rust, soot, or scale accumulations are found, call your servicing dealer. **DO NOT OPERATE THE FURNACE.**

⚠ WARNING

If holes are found or if the vent pipe is obstructed or is not connected, toxic fumes can escape into your home. DO NOT OPERATE YOUR FURNACE. Call your dealer for service. A failure to follow this warning could result in personal injury or death.

3. Inspect the vent pipe for a sag, holes, or a disconnection. A horizontal vent pipe must slope upward. If rusty joints or seams, or signs of water leakages are found, call your dealer for service.
4. Replace the access doors and restore electrical supply to the furnace. Be sure bottom door flange is inside of the furnace casing. (See Fig. 16 and 17.)
5. Start the furnace and observe its operation. If possible, watch the burner flames. Are they burning bright blue? If not or if you suspect some other malfunction, call your servicing dealer.

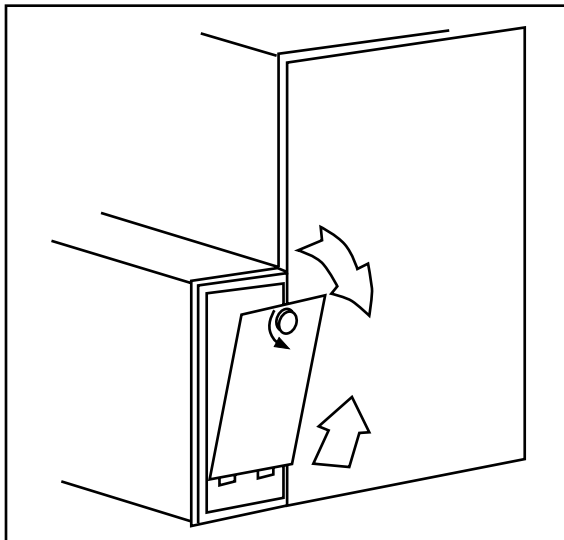

30

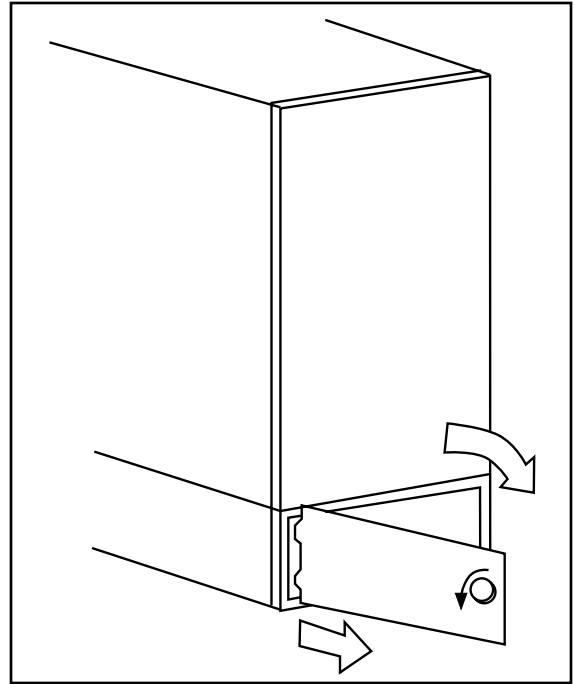

31

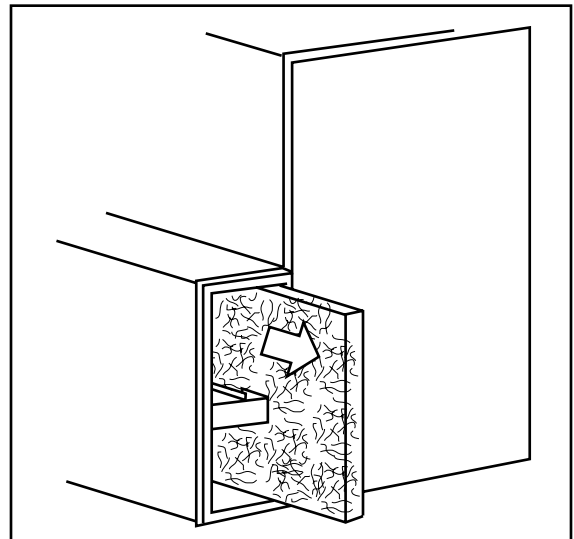

32

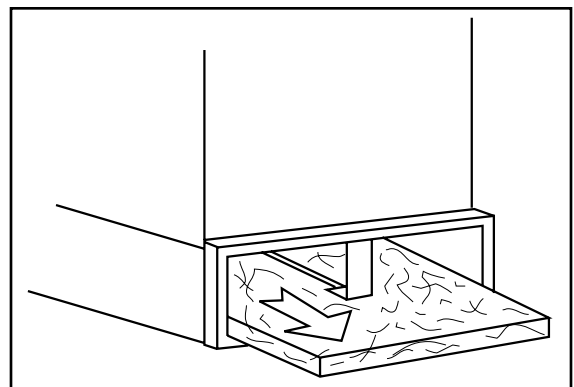

33

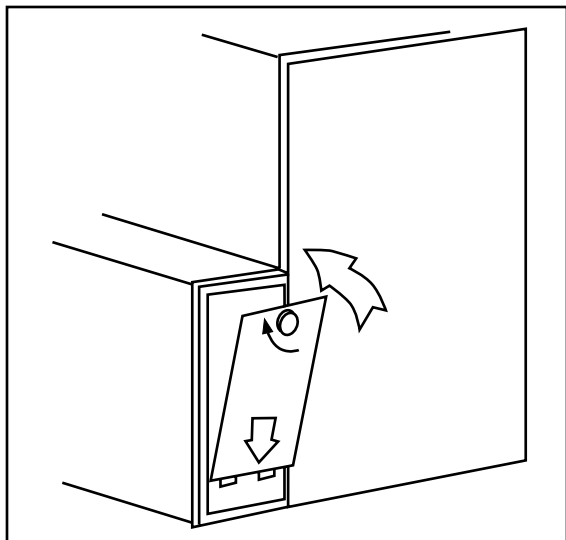

34

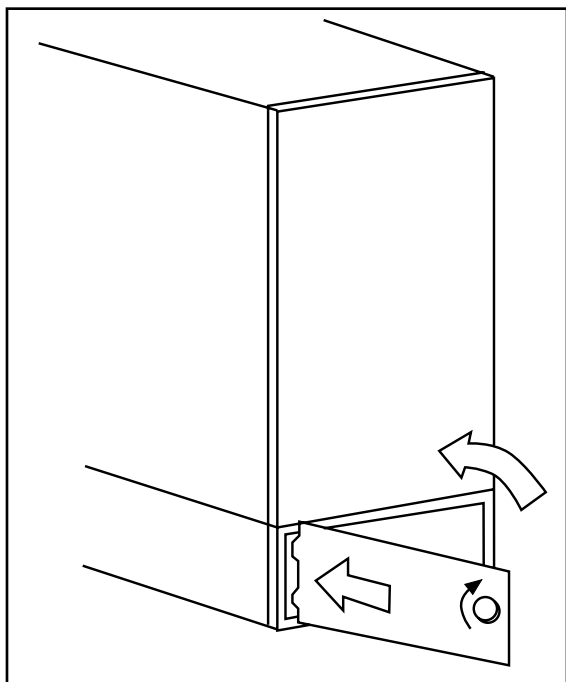

35

BEFORE YOU REQUEST A “SERVICE CALL”

Before you call for service, check for several easily solved problems:

- Check for sufficient airflow. Check the air filter for dirt. Check for blocked return-air or supply-air grilles. Be sure they are open and unobstructed. If this isn't the cause of the problem, call your servicing dealer.

If your furnace isn't operating at all, check the following list for easily solved problems:

- Is your thermostat set above room temperature? Is the switch in the HEAT position?
- Is the electrical power supply switch on? Is the blower access door firmly in place? Are any fuses blown? (There is a fuse on the furnace control.) Has a circuit breaker tripped?

- Is the manual shut-off valve in the gas supply pipe leading to the furnace open? Does the lever point in the same direction that the pipe runs (open)? Or is it at a right angle to the pipe (closed)?

NOTE: Before proceeding with the next checks, turn off the electrical power supply to the furnace. Remove access doors.

- Is the control knob or switch on the gas valve turned to the ON position? If this or the preceding check shows an interruption in the gas supply, make sure the gas has not been shut off for safety reasons. If nothing else seems to be wrong, follow the startup procedures found on pages 4 and 5 of this booklet.
- If for some reason the vent is blocked, the draft safeguard switch will shut off the furnace. Reset the switch by pushing the button located on top of the switch. See page 2 or 3 for switch location.

If the switch trips a second time, turn off the furnace and call for service.

- **Downflow/Horizontal Only**—Check the manual reset auxiliary limit switch located on the blower housing. If the blower motor fails, this switch will shut off the furnace. Reset it by pushing the button on the switch. If it trips again, turn off the furnace and call for service.

- Check the manual reset flame rollout switch(es) located near the burners. If the furnace has experienced a high-temperature condition due to inadequate combustion air, these switches will shut off the furnace. Reset the switch(es) by pushing the button on the switch. If the switch trips a second time, turn off the furnace and call for service.

- If your furnace still fails to operate, call your servicing dealer for troubleshooting and repairs. Tell your dealer the model and serial numbers for your furnace. (You should have them recorded on page 8 of this booklet.) By knowing exactly which furnace you have, the dealer may be able to offer suggestions over the phone or save valuable time through knowledgeable preparation for the service call.

- **Your furnace control board has an LED fault code light that indicates the furnace status.** The LED will flash short and long flashes. Look through the sight glass on the furnace door and determine the code (number of short and long flashes). Give the code and furnace model number to your dealer when you call. By knowing exactly which furnace you have and the LED code being displayed, your dealer can save valuable time through knowledgeable preparation for the service call.

Regular dealer maintenance

In addition to the type of routine maintenance you might be willing to do, your furnace should be inspected regularly by a properly trained service technician. A semiannual inspection (or annual inspection, at least) should include the following:

1. Inspection of all flue product passages including the burners, heat exchanger, relief box, and vent pipe.
2. Inspection of all combustion and ventilation air passages and openings.
3. Close check of all gas pipes leading to and inside of your furnace.
4. Inspection, cleaning, and lubrication (when required) of the blower motor and wheel.

NOTE: Refer to the unit Service Procedures for blower motor oiling information. When required, the motor must be oiled by a qualified service technician.

5. Routine inspection and cleaning/replacement of the air filter.
6. Inspection of all supply- and return-air ducts for obstructions, air leaks, and insulation. Any problems found should be resolved at this time.

7. Inspect the return-air duct connection(s) at the furnace to ensure it is physically sound, sealed to the furnace casing, and terminates outside the space containing the furnace.
 8. Inspection of furnace installation for proper support and any obvious deterioration of the furnace. The support must be sound and without sags, gaps, cracks, etc., around the furnace base so as to provide an air seal between the support and furnace.
 9. A check for loose connections attaching individual components. Inspection of all electrical wiring and their connections.
 10. Operational check of the furnace itself to determine working condition. Repair or adjustment should be made at this time.
- Ask your servicing dealer for further details about an economical service contract that covers seasonal inspections.

INSTALLATION DATA

Date Installed _____

Dealer Name _____

Address _____

City _____

State _____ Zip _____

Telephone _____

FURNACE

Product No. _____

Model No. _____

Serial No. _____

SPLIT-SYSTEM

OUTDOOR UNIT:

Product No. _____

Model No. _____

Serial No. _____

INDOOR COIL:

Product No. _____

Model No. _____

Serial No. _____



Carrier

A United Technologies Company

TO OBTAIN INFORMATION ON PARTS: Consult your installing dealer or the classified section of your local telephone directory under the "Heating Equipment" or "Air Conditioning Contractors & Systems" heading for dealer listing by brand name. Have available the Model No., Series Letter, & Serial No. of your equipment to ensure correct replacement part.

Carrier Corporation 7310 West Morris St. Indianapolis, IN 46231

Manufacturer reserves the right to discontinue, or change at any time, specifications or designs without notice and without incurring obligations.